

Phase Matrix, Inc.

Instruments You Can Count On

585C

588C

595A

598A

Pulse/CW Frequency Counters with Peak Power (595A/598A)



- Pulse and CW Frequency Measurement to 170 GHz
- Peak Power Measurement to 26.5 GHz
- Built-in Pulse Profiling
- 200 Watt (+53 dBm) Burnout Protection

EIP/Phase Matrix Pulse/CW Microwave and Millimeter-Wave Counters

***Automatic Acquisition and Profiling
(Both Frequency and Power) with the Broadest
Frequency Measurement Coverage: 100Hz to 170GHz***

585C / 588C full function pulse/CW counters with an optional internal delaying pulse generator for the ultimate in ease-of-use

595A / 598A add practical peak and CW power measurements to the capability of the 585C/588C

Phase Matrix brings to you the broadest spectrum of pulse and CW microwave and millimeter-wave frequency counters available today. These models offer automatic and self contained frequency and power profiling that is ideally suited to such applications as chirped radar analysis, VCO measurement, and frequency agile system analysis over a frequency range up to 170 GHz (depending upon the model selected).

Pulsed or CW Measurements to 170 GHz

The 588C and 598A extended frequency capability enables CW measurements from 100 Hz to 170 GHz, and pulsed measurements from 250 MHz to 170 GHz. Parameters such as frequency, power (595A/598A only), pulse width, pulse period, or PRF can all be measured fully automatically. The 585C/588C and the 595A/598A will detect and measure CW, frequency modulated, amplitude modulated, or pulsed RF signals with pulse widths as narrow as 50nS.

Automatic Peak Power

The 595A/598A greatly simplify the measurement of peak power in your application. By measuring the frequency of the incoming signal, the instrument automatically corrects the power reading for the Calibration Factor of the internal sensor. You no longer have to manually enter the Calibration Factors or the measurement frequency. Careful design and internal calibration tables result in excellent accuracy and repeatability.



Phase Matrix's frequency selective heterodyne technique with unique YIG filter frontend offers benefits not available in any other counter.

Self-Contained Profiling of Frequency and Power

The optional built in delaying pulse generator enables completely self-contained frequency and power profiling measurements. Synchronous outputs on the rear panel show actual measurement window for viewing on an oscilloscope. In addition, automatic measurements of pulse width, pulse period and pulse repetition frequency simplify your measurement task.

True profiled measurements are possible with a sample window as narrow as 15nS. Careful design consideration was given to accurately and automatically measuring rapidly varying pulse bursts as might be typical in the generation of frequency hopping or wide band chirp signals. The Phase Matrix/EIP Model 595A/598A and 585C/588C actually reacquire the microwave signal for each measurement window, allowing, essentially, unlimited frequency changes from window to window. Competitive techniques require external gating if the frequency changes more than 10 MHz within the detected burst.

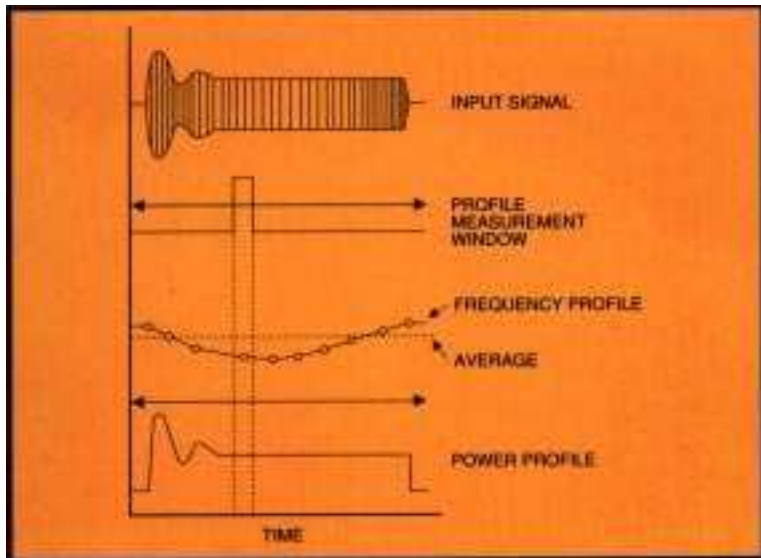

Frequency and power can be automatically profiled with the optional internal delaying pulse generator

Unmatched Frequency Selectivity

Only Phase Matrix/EIP counters utilize the proven YIG Preselected Heterodyne Down Conversion technique. This spectrum analyzer type preselector prevents harmonics and other spurious signals from interfering with the measurement of the desired signal. Additionally, it totally eliminates “kickback” noise. Furthermore, this frequency selectivity allows the user to select any desired signal for measurement of both power and frequency in a multi-signal environment.

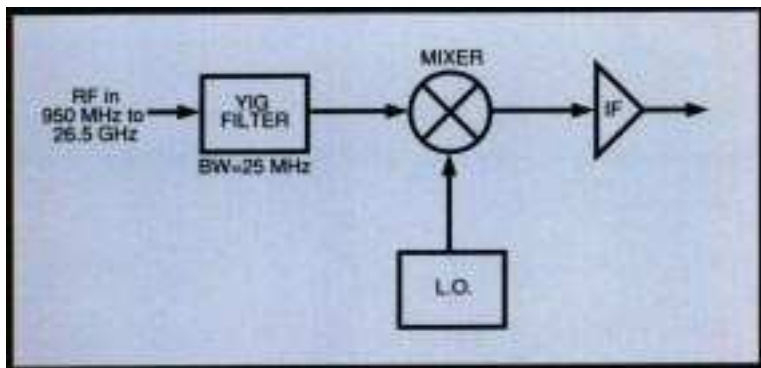

All Phase Matrix Counters features the unique YIG Preselected Heterodyne Down-Converter.

Graceful Overload Protection to 200 Watts

The YIG filter provides effective power limiting to protect against burnout due to accidental application of high-level signals, yet does not reduce sensitivity. This greatly reduces down time, especially in the hands of unskilled operators. At remote sites, this high-level burnout protection often proves invaluable by reducing the need for additional trips if a high power signal is accidentally connected to the counter's input.

Full Environmental Compliance

The Phase Matrix/EIP 595A/598A and 585C/588C are in full EMI/RFI environmental compliance with MIL-STD-461 and MIL-T-28800, Type III, Class 5. As well as CE certified to EN50011 and EN50082-1.

Full Programmability

These counters have been optimized for integration into ATE systems and have all the systems characteristics you need for your test applications. All front panel controls, data output format and special functions are controllable over GPIB. Also, rear panel inputs simplify the integration of your system.

High Stability Time Bases

Optional ovenized time bases provide higher accuracy and lower cost of ownership. The time base component of error is dramatically reduced with these high-stability time bases. The only periodic maintenance required on the 595A/598A and 585C/588C is time base calibration. With aging rates as low as 2×10^{-7} /year, the calibration cycle can be extended to two years while maintaining kHz accuracy on a 20 GHz frequency measurement.

Proven Reliability

The predecessors to the Phase Matrix models 595A/598A and 585C/588C, (EIP 585 and 588, introduced in 1985), have become standards of reliability, achieving a field proven MTBF in excess of 40,000 hours. Phase Matrix is so confident in the quality and reliability of these products that we back them with an optional three year warranty.

Automatic Pulsed/CW Frequency and Power Measurements

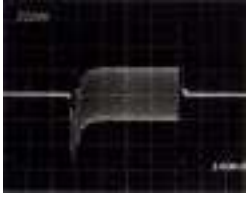

Photo 1

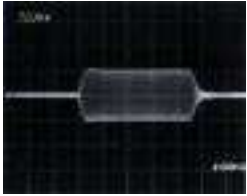

Photo 2

Photo 1 shows extreme video distortion interference on the incoming RF. Photo 2 shows the same RF signal after processing by the Phase Matrix YIG Preselected Heterodyne Down-Converter input filter, with error causing video component removed.

- 1. Automatic Pulsed Millimeter-Wave Counting up to 170 GHz** with the addition of the Model 890 cable kit and one or more harmonic mixers. Large amounts of “chirp”, often encountered in millimeter-wave signals, can be precisely counted using Center Frequency Mode.
- 2. Model 595A/598A Power Measurement Capability** operates over the full operating range of the Band 1 and 2 inputs on both CW and pulsed signals.
- 3. Phase Matrix’s Unique YIG Preselector** provides an excellent combination of burnout protection, sensitivity, frequency selectivity and video immunity. The inherent frequency selectivity of the YIG filter allows counting the highest amplitude signal even with many other signals present.
- 4. Optional Internal Pulse Generator** makes the profiling of frequency and power simple and automatic.
- 5. Pulse Width or Pulse Period** can be measured and displayed with a touch of the Pulse Width or Pulse Period key. Pulse repetition frequency can also be easily displayed.
- 6. Frequency High/Low Limit** allows the measurement of a lower amplitude signal in the presence of higher amplitude signals.
- 7. External Switching Requirements Eliminated** by the use of four independent signal inputs that let the operator apply multiple signals and measure any one by merely switching the band selector from the keyboard or over the IEEE-488 Bus.





8. **Dual Display For Fast, Easy Readout** simultaneously provides two important signal parameters: 1) Frequency to 1 kHz resolution, and either 2) Power to 0.1 dB resolution or 3) Pulse width (or pulse period) to 10 nanosecond resolution. The three-digit (or six digits with special function mode) pulse period/pulse width display utilizes a floating decimal format with annunciators.
9. **Automatic Power-Up Self-Testing and Go-to-Local** allows one key stroke to switch from remote to local, or to fully initialize the system from local. When initialized, the instrument automatically executes power-up self-tests.
10. **Precise Pulse Measurements Provided by the IF Threshold and Gate Outputs.** These convenient outputs allow the operator to monitor exactly where within the RF pulse the sample is taken. This feature is especially useful when using external gating for frequency profiling.
11. **All Front Panel Functions and Test Sequences Can Be Placed Under GPIB Control** via the IEEE-488 bus for ATE applications.
12. **Optional Rear Panel Inputs** simplify signal routing in rack-mounted applications.
13. **External Time Base Reference Capability** allows the use of an external 10 MHz reference as a common system time base. Or use the output of the optional ovenized oscillator as the system time base.



SPECIFICATIONS

	BAND 1	BAND 2	BAND 3 (Option 5804)
Frequency Range	0.25 - 1 GHz	595A & 585C: 0.95 - 20 GHz 598A & 588C: 0.95-26.5 GHz	26.5-170 GHz
Sensitivity	-20dBm	0.95 - 2GHz -20 dBm 2 - 12.4 GHz -25 dBm 12.4 - 20 GHz -20 dBm 20 - 26.5 GHz -15 dBm	-20 dBm (26.5 to 60 GHz) -15 dBm (60 to 170 GHz)
Connector	BNC	595A & 585C: Precision N 598A & 588C: APC 3.5	Depends on remote sensor (See Table)
Impedance	50 Ω nominal	50 Ω nominal	N/A
Maximum Input Damage Level	+7 dBm +27 dBm	+7 dBm +45 dBm CW +53 dBm peak pulsed (≤1μS pulse, 0.1% duty cycle)	+5 dBm +10 dBm
Amplitude Discrimination	15 dB	15 dB (>50 MHz separation)	20 dB
Frequency Limits	N/A	Instrument will reject signals >50 MHz outside of Limits Resolution: 10MHz	N/A
Center Frequency	N/A	Instrument will reject signals >50 MHz outside the specified Delta Frequency. Resolution: 10MHz 20 MHz P-P	Instrument assumes any signal present to be in the range ±2 GHz from the specified center frequency. Auto Mode: 20MHz P-P Center Freq: 150 MHz P-P
FM Tolerance (up to 10 MHz rate)	Carrier must remain in band		
Acquisition Time* Pulse	$AQ = \left\{ \frac{1}{MINPRF} \right\} + 0.05$	$AQ = 2(FH) \left[(4 \times 10^{-12}) + \frac{(4 \times 10^{-8})}{MINPRF} \right] + \frac{60}{MINPRF} + \frac{(2 \times 10^{-5})(PP)}{GW} + 0.3$	Automatic: $AQ = \frac{70}{MINPRF} + \frac{(6 \times 10^{-3})(PP)}{GW} + 0.2$ Center Frequency: $AQ = \frac{70}{MINPRF} + \frac{(8 \times 10^{-4})(PP)}{GW} + 0.2$
CW	$AQ = \left\{ \frac{1}{MINPRF} \right\} + 0.05$	$AQ = 2(FH) \left[(4 \times 10^{-12}) + \frac{(4 \times 10^{-8})}{MINPRF} \right] + \frac{60}{MINPRF} + 0.3$	$AQ = \frac{70}{MINPRF} + 0.2$
Measurement Time² Pulse	$MT = \frac{(4)(PP)}{(GW)(RES)} + 0.05$	$MT = \frac{(PP)}{(GW)(RES)} + 0.05$	$MT = \frac{(4)(PP)}{(GW)(RES)} + 0.05$
CW	$MT = \frac{(4)}{(RES)} + 0.05$	$MT = \frac{1}{(RES)} + 0.05$	$MT = \frac{4}{(RES)} + 0.05$
Gate Error²	$GE = \pm \frac{0.07}{GW}$	$GE = \pm \frac{0.01}{GW}$	$GE = \pm \frac{0.03}{GW}$
Distortion Error²	$DE = \pm \frac{0.03}{PW - (3 \times 10^{-8})}$	$DE = \pm \frac{0.03}{PW - (3 \times 10^{-8})}$	$DE = \pm \frac{0.02}{PW - (3 \times 10^{-8})}$
Averaging Error²	$AE = \pm 2 \times \sqrt{\frac{RES}{(GW)(AVG)}}$	$AE = \sqrt{\frac{RES}{(GW)(AVG)}}$	$AE = \pm 2 \times \sqrt{\frac{RES}{(GW)(AVG)}}$
Total Error² Pulse	$TE_p = \pm AE \pm GE \pm DE \pm \text{TimeBaseError}$	$TE = \pm AE \pm GE \pm DE \pm \text{TimeBaseError}$	$TE = \pm AE \pm GE \pm DE \pm \text{TimeBaseError}$
CW	$TE_{CW} = \text{TBError} \pm 1 \text{ count}$ (Based on 10 averages)	$TE_{CW} = \text{TBError} \pm 1 \text{ count}$ (Based on 10 averages)	$TE_{CW} = \text{TBError} \pm N^2 \text{ counts}$ (where $N = \frac{\text{freq}}{20\text{GHz}}$)

SPECIFICATIONS

BAND 0 (CW only)

Frequency Range	100 Hz - 250 MHz
Sensitivity	-20dBm
Connector	BNC
Input Impedance	50 ohms nominal
Maximum Input	+7 dBm
Damage Level	+27 dBm
FM Tolerance	Carrier must remain in band
Measurement Time	(1/RES) + 50ms
Total Error²	TE = Time Base Error ± Count

BAND 3

Model 588C/598A Frequency extended, in bands, up to 170GHz. This requires Option 5804, a frequency extension cabling kit (890), and one or more of the following remote sensors:

Remote Sensor	Frequency Range	WaveGuide Size	WaveGuide Flange
091	26.5 - 40 GHz	WR-28	UG-599/U
092	40 - 60 GHz	WR-19	UG-383/U
093	60 - 90 GHz	WR-12	UG-387/U
094	90 - 110 GHz	WR-10	UG-387/U
095	50 - 75 GHz	WR-15	UG-385/U
096	33 - 50 GHz	WR-22	UG-383/U
097	26.5 - 50 GHz	K - Conn.*	Coaxial
098	110 - 170 GHz	WR - 6	UG-387/U

STANDARD TIME BASE

Crystal Frequency	10MHz (TXCO)
Stability	
Aging Rate	<1 x 10 ⁻⁷ /month
Short Term	<1 x 10 ⁻⁹ RMS, 1s average
Temperature	<1 x 10 ⁻⁶ , 0° to 50°C
Line Variation	<1 x 10 ⁻⁷ , ± 10% Line voltage change
Warm-Up Time	None required
Output Frequency	10 MHz square wave, 1V p – p minimum into 50 ohms.
External Time Base	Requires 10 MHz square wave, 1V p – p minimum into 300 ohms.

OPTIONAL HIGH-STABILITY OVENIZED TIME BASE

Option	5809
Aging Rate per 24 hrs (after 72 hours warm-up)	<5 x 10 ⁻¹⁰
Short Term Stability 1s Average (RMS)	<1 x 10 ⁻¹⁰
Temperature Stability (0° - 50°C)	<3 x 10 ⁻⁹
±10% Line Voltage Change	<2 x 10 ⁻¹⁰

Note 2 AE = RMS averaging error (Hz) FH = Difference between Frequency Limit High and Low (Hz)
 AQ = Acquisition time (seconds)
 AVG = Number of averages GE = Gate error (Hz)
 DE = Distortion error (Hz) TE = Total error (Hz)

*K-Connector is a registered trademark of Wiltron Company
 Specifications subject to change without notice.

PULSED MEASUREMENTS

Pulse Width	50 ns - CW
Minimum Profile Sample	15 ns frequency/100 ns power
Pulse Repetition Frequency (PRF)	1 Hz - 4 MHz
Minimum Off Time	200 ns (will count CW)
Minimum On/Off Ratio	15 dB

PULSE PARAMETER MEASUREMENTS

	Pulse Width	Pulse Period
Range	50ns - 1 s	250 ns - 1 s
Resolution	10 ns	10 ns
Measurement Points	-6 dB ± 1.5 dB	-6 dB ± 1.5 dB
Accuracy	±20 ns (Timebase Error x PW)	

PULSE GENERATOR SPECIFICATIONS

	Min	Max	Resol.
Delay	74 ns	800 ms	2 ns
Width	24 ns	800 ms	2 ns
Period	100 ns	800 ms	50ns
Trig In	TTL, 1kΩ input		
Trig Out	TTL, into 50Ω, 50 to 100 ns width		
Pulse Out	TTL, into 50Ω		

POWER MEASUREMENT (595A AND 598A ONLY)

Measured power of signals (pulsed and CW) applied to band 1 and 2 inputs. Power and frequency are simultaneously displayed to 0.1 dB and 100 kHz resolution, respectively. Power off sets from +99.9 dB to -99.9 dB (0.1 dB resolution) can be input from the keyboard for via GPIB.

Frequency Range	250 MHz - 20 GHz (595A) 250 MHz - 26.5 GHz (598A)
Resolution	0.1 dB
Dynamic Range	Same as counter operation range
Measurement Window	25 MHz nominal
Minimum Pulse Width	100 ns (internal or external gating)
Measurement Time	Frequency measurement time plus one gate time plus 150 msec - CW
Accuracy	±0.5 dB CW typical (25°C, input padded by 3 dB) ±1.5 dB CW typical (25°C, input padded by 3 dB, 1µsec measurement window, 10% duty cycle)
Repeatability	±0.3 dB typical CW to 20 GHz ±0.5 dB typical CW to 26.5 GHz ±0.3 dB typical pulse to 20 GHz (1µsec measurement window, 10% duty cycle) ±0.8 dB typical pulse to 26.6 GHz (1µsec measurement window, 10% duty cycle)

GW = Logical AND of inhibit input and pulse width -3 x 10⁻⁶ (seconds)
 MinPRF = Minimum PRF counter setting (Hz); for MinPRF>1.2 kHz, use MinPRF = 1200
 MT = Measurement Time (seconds)
 PP = Pulse period (seconds)
 PW = Pulse width (seconds)
 RES = Counter resolution setting (Hz); for RES>1MHz, use RES = 10%

GENERAL

Dimensions	3.5 in H x 16.75 in W x 14 in D (8.9 cm H x 42.6 cm W x 35.6 cm D)	Warranty	1 Year Standard (Extendable to 3 years)
Weight	≈ 35 lbs., 15.9 Kg	Computer Interface	GPIO (IEEE-488/1987)
Shipping Weight	≈ 40 lbs., 18.2 Kg	Certifications	CE Certified for EMC to EN50011 and EN50082-1
Operating Temperature	0 to 50°C		CE Certified for Safety to IEC 1010-1 (1990)
Power	100/120/200/240 Vac ± 10% 50 - 400 Hz, 100 VA typical		
Resolution	1 Hz to 1 GHz		
Gate Time	1 s to 1μs (dependent upon resolution)		

ORDERING INFORMATION

Model 585C	Pulse/CW Microwave Frequency Counter, 20 GHz
Model 588C	Pulse/CW Microwave Frequency Counter, 26.5 GHz
Model 595A	Pulse/CW Microwave Frequency Counter, 20 GHz with Peak Power Measurement
Model 598A	Pulse/CW Microwave Frequency Counter, 26.5 GHz with Peak Power Measurement

FREQUENCY EXTENSION ACCESSORIES FOR MODEL 588C/598A

	Waveguide Size	Waveguide Flange
890	Frequency Extension Cable Kit	
091	Remote Sensor 26.5 - 40 GHz	WR-28 UG -599/U
092	Remote Sensor 40 - 60 GHz	WR-19 UG-383/U
093	Remote Sensor 60 - 90 GHz	WR-12 UG-387/U
094	Remote Sensor 90 - 110 GHz	WR-10 UG-387/U
095	Remote Sensor 50 - 75 GHz	WR-15 UG-385/U
096	Remote Sensor 33 - 50 GHz	WR-22 UG-383/U
097	Remote Sensor 26.5 - 50 GHz	K-Conn Coaxial
098	Remote Sensor 110 - 170 GHz	WR-6 UG-387/U

Note: Remote Sensors require cable kit 890 and extended frequency Option 5804.

OPTIONS

5803	Rear Panel Input Connectors
5804	Band 3 Frequency Extension Module Available on Model 588C/598A only.
5809	Ovenized High Stability Timebase (Aging Rate: 5×10^{-10}/day)
5810	Delaying Pulse Generator
14	2 Year Warranty Extension (to 3 years total)
15	MIL-STD 45662A Data and Certification

ACCESSORIES

010	Transit Case
021	Rack Mount Kit with Handles
022	Rack Mount Kit without Handles
031	Extra Operations Manual (one supplied at no cost)
032	Maintenance and Service Manual (includes operations information)
043	Service Kit
050	Sof-Pac Carrying Case
101	Chassis Slide Kit with Handles (includes 021)
102	Chassis Slide without Handles (includes 022)

For More Information Contact:

Phase Matrix, Inc.
109 Bonaventura Drive
San Jose, CA 95134 U.S.A

TEL: (408) 428-1000
FAX: (408) 428-1500
TOLL FREE: (877) 4PhaseM
EMAIL: sales @phasematrix.com